



Strut Pipe Clamp

OD

Technical Features

- **Sizes (Pipe Diameter):** 21mm through 221mm
- **Finish :** Electro Zinc Plated
- **Specification :** Compatible with Strut Channels and Cantilever Struts. Hex screw with slot.
To fix pipes and cables.
Supplied with screw and nut

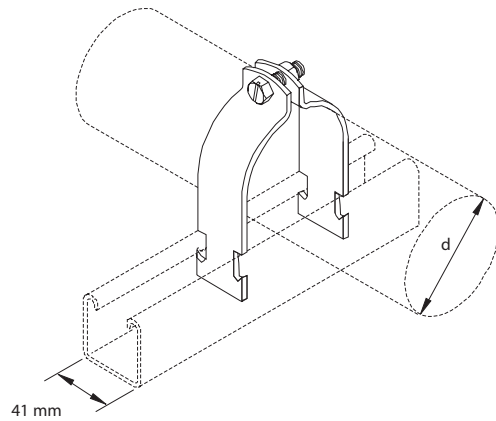

Pipe Support

Strut Pipe Clamp - OD

Physical Data

Reference	Nominal Pipe Size		d (mm)	Box Qty.	Weight (x1) (kg / lbs)
	metric (DN)	inch			
598816	DN15	1/2"	21-23	100	0,06 / 0.13
598818	DN20	3/4"	26-29	100	0,06 / 0.13
598822	DN25	1"	32-36	50	0,07 / 0.15
598825	DN32	1 1/4"	42-45	50	0,07 / 0.15
598826	DN40	1 1/2"	46-50	50	0,08 / 0.18
598831	DN50	2"	60-63	25	0,13 / 0.29
598835	DN65	2 1/2"	71-74	25	0,16 / 0.35
598836	DN65	2 1/2"	74-77	25	0,17 / 0.36
598839	DN80	3"	86-90	25	0,23 / 0.50
598845	DN100	4"	112-115	25	0,28 / 0.61
598853	DN125	5"	138-141	25	0,45 / 0.99
598857	DN150	6"	164-167	25	0,65 / 1.43
598858	DN150	6"	167-170	25	0,69 / 1.52
598865	DN200	8"	218-221	1	0,99 / 2.19